

KM-1601S_H(3)

STACKABLE CRESCENT CUBER

Item # _____

Project: _____

Qty: _____

*AutoCad available on KCL

KM-1601S_H(3)

4/08

Item # 13204

CUBER DIMENSIONS

W x D x H

KM-1601S_H(3)
48 x 27^{3/8} x 27^{3/8}

CONDENSING UNIT DIMENSIONS

W x D x H

Installation Dimensions

URC-21F

48^{7/16} x 18^{1/8} x 40^{7/8}*
*with legs

Actual Dimensions

URC-21F

46^{3/8} x 15^{11/16} x 25^{15/16}

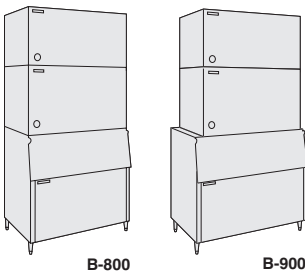
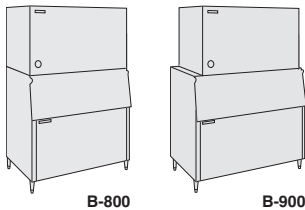

Also available on Large Bins:
B-1150SS
B-1300SS
B-1500SS
B-1650SS

KM-1601SWH

Water-Cooled 1 Phase

KM-1601SWH3

Water-Cooled 3 Phase

KM-1601SRH



Remote Air-Cooled 1 Phase

KM-1601SRH3

Remote Air-Cooled 3 Phase

Shown on an optional
B-900



- Up to 1585 lbs. of ice production per 24 hours
- Durable stainless steel exterior
- Individual crescent cube
- Protected by *HoshiGuard* Antimicrobial Agent 
- CycleSaver® Design 
- EverCheck® alert system 
- Stainless steel evaporator
- Stackable for 3170 lbs. of ice production in the same floor space
- R-404A Refrigerant
- Complies with California Energy Commission guidelines (CEC)

* The KM-1601-SRH is ENERGY STAR certified.

Warranty

Valid in United States, Canada, Puerto Rico, & U.S. Territories. Contact factory for warranty in other countries.

Three Year - Parts & Labor on entire machine.

Five Year - Parts & Labor on: Evaporator.

Five Year - Parts on: Compressor, air-cooled condenser coil.



© HOSHIZAKI AMERICA, INC.

618 Hwy. 74 S., Peachtree City, GA 30269

TEL 1-800-438-6087

FAX 1-800-345-1325

www.hoshizaki.com



KM-160IS_H(3) STACKABLE CRESCENT CUBER

DIMENSIONS
W x D x H
KM-160IS_H(3)
48 x 27^{3/8} x 27^{3/8}

Installation Dimension
URC-21F
48^{7/16} x 18^{1/8} x 40^{7/8}
*with legs

Actual Dimension
URC-21F
46^{3/8} x 15^{11/16} x 25^{15/16}

WATER-COOLED | PHASE / 3 PHASE

| Water Temp° F. | 50° | 70° | 90° |
|------------------|-------------|-------------|-------------|
| Air Temp° F. 70° | 1492 / 1555 | 1501 / 1558 | 1419 / 1466 |
| Air Temp° F. 80° | 1499 / 1557 | 1513 / 1562 | 1378 / 1417 |
| Air Temp° F. 90° | 1501 / 1558 | 1523 / 1565 | 1408 / 1440 |

REMOTE AIR-COOLED | PHASE / 3 PHASE

| Water Temp° F. | 50° | 70° | 90° |
|------------------|-------------|-------------|-------------|
| Air Temp° F. 70° | 1564 / 1585 | 1547 / 1563 | 1468 / 1464 |
| Air Temp° F. 80° | 1551 / 1568 | 1524 / 1535 | 1415 / 1396 |
| Air Temp° F. 90° | 1547 / 1563 | 1505 / 1511 | 1407 / 1387 |

UTILITY CONSUMPTION

| Model Number | Ice Production Per Cycle Lbs. Cubes | KWH per 100 LBS. 90/70 | Potable Water Gal. per 100 lbs. | Condenser Water Gal. per 100 lbs. |
|--------------------------|--|---------------------------|---------------------------------|-----------------------------------|
| KM-1601SWH | 30.2 1440 | 3.8 | 24.5 | 98 |
| KM-1601SWH3 | 30.2 1440 | 3.7 | 23.8 | 100 |
| KM-1601SRH with URC-21F | 31.2 1440 | 4.3 | 24.9 | N/A |
| KM-1601SRH3 with URC-21F | 31.2 1440 | 4.7 | 24.0 | N/A |

SPECIFICATIONS

| Model Number | Condenser | Amperage | Min. Circuit Ampacity | Shipping Weight |
|--------------|-------------------|----------|-----------------------|-----------------|
| KM-1601SWH | Water-Cooled | 13.4 | 20 | 360 lbs. |
| KM-1601SWH3 | Water-Cooled | 9.0 | 20 | 360 lbs. |
| KM-1601SRH | Remote Air-Cooled | 12.8 | 20 | 350 lbs. |
| KM-1601SRH3 | Remote Air-Cooled | 7.9 | 20 | 350 lbs. |

STORAGE BINS

| Model Number | Application Capacity | ARI-Rated Capacity |
|--------------|----------------------|--------------------|
| B-800 | 800 lbs. | 600 lbs. |
| B-900 | 900 lbs. | 660 lbs. |
| B-1150 | 1150 lbs. | N/A |
| B-1300 | 1275 lbs. | N/A |
| B-1500 | 1500 lbs. | N/A |
| B-1650 | 1605 lbs. | N/A |

ELECTRICAL & PLUMBING/KM-160IS_H(3)

- 208-230V/60/1/3 wire with dedicated neutral for 115V / (208-230/60/3)
- 20 amp Max Fuse/HACR Breaker Size
- 1/2" OD copper or equivalent independent potable water supply
- 3/4" FPT independent drain connection



© HOSHIZAKI AMERICA, INC.

618 Hwy. 74 S., Peachtree City, GA 30269

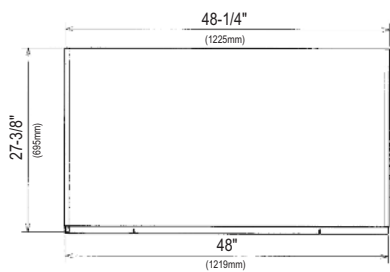

FRONT VIEW

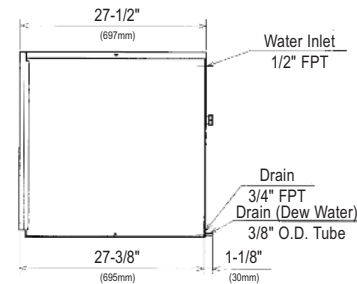

SIDE VIEW

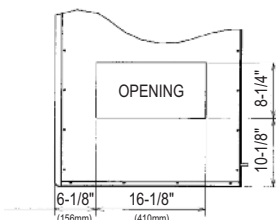

ICE DROP ZONE

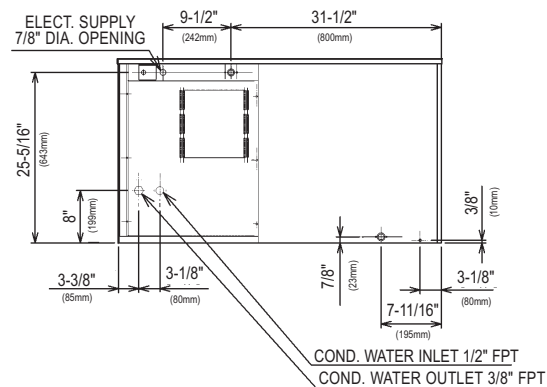

WATER-COOLED UNIT

URC-21F Remote Condensing Unit (Sold Separately)
For Use with KM-1601SRH(3)

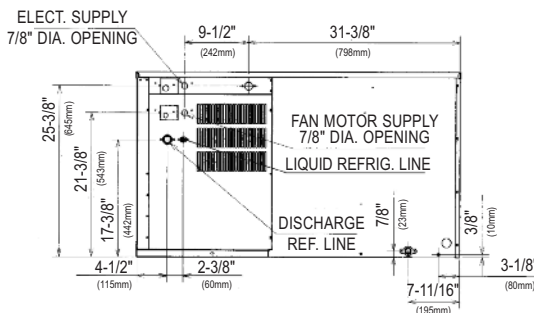

REMOTE AIR-COOLED UNIT

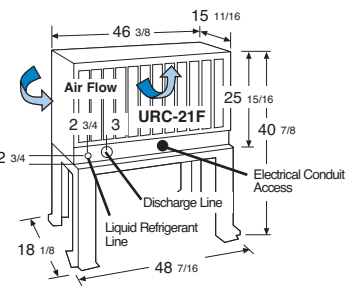

Pre-Charged Tubing Kit
(Sold Separately)
20' R404-20610
35' R404-35610
55' R404-55610

Voltage supply for the URC Remote Condenser is supplied from the Ice Maker. No additional circuit is required.

OPERATING LIMITS

- Ambient Temp Range 45 - 100°F
- Water Temp Range 45 - 90°F
- Water Pressure 10 - 113psig
- Voltage Range 187 - 253V

CONDENSING UNIT

- Voltage Range 104 - 127V
- Ambient Temp Range -20 - 122°F

SERVICE

- Panels easily removed and all components accessible for service.

TEL 1-800-438-6087

FAX 1-800-345-1325

www.hoshizaki.com

Printed in U.S.A.

